



GORE™ Single-Use Valve

FOR STEAM-IN-PLACE APPLICATIONS

Ensures controlled aseptic dispensing of bioprocess fluids

Product Description

The GORE™ Single-Use Valve provides positive flow control in pharmaceutical and biotherapeutic fluid dispensing applications, where high purity is required. It is ideally suited for barb-fitting or silicone-molded connection to disposable fluid transport systems. When used as the primary connection interface between a vessel port and a closed, pre-sterilized disposable assembly, it enables the assembly to remain aseptic throughout the connection, SIP, and fluid transfer processes. The unique platinum-cured silicone valve body liner creates a continuous, seamless, single-material contact surface for high value fluids. The liner's one-piece molded construction extends from the device face as a sealing gasket for sanitary end fittings and has a 0.25" (6 mm) ID tube extending from the valve body to enable easy connection to single-use assemblies. With higher flow rates than alternative valves, delivery time is minimized.

Quality Assurance

The GORE™ Single-Use Valve is designed to meet the most demanding requirements of biocompatibility, and all components meet or exceed the test requirements of:

- USP Class VI for Plastics
- USP <661> Physiochemical Tests
- FDA 21 CFR 177
- EP 3.1.9. — Silicone elastomer for closures and tubing

Critical properties are controlled throughout the manufacturing process, which operates under a quality system based on applicable current Good Manufacturing Practices (cGMP). Additionally, GORE™ Silicone Tubing is animal derived component free (ADCF).

Materials of Construction

Valve body Platinum-cured silicone (PCS)

Housing and knobs . . . Polyetherimide (PEI)

Dowel Pin Stainless Steel (SS)

Chemical Compatibility Guidelines

	Acids		Bases		Salts	Alcohols	Ketones
	Strong	Weak	Strong	Weak			
PCS	N	Y	N	Y	Y	Y	Y
PEI	Y	Y	Y	Y	Y	Y	N
SS	N	Y	Y	Y	Y	Y	Y

Y = Yes N = No



Benefits of the GORE™ Single-Use Valve

- Minimizes the risk of cross-contamination via a single-use preassembled system
- Reduces the risk of particle entrapment through unique crevice-free design
- Simplifies connection to standard sanitary end connections by eliminating the need for seals, o-rings or gaskets
- Enables higher flow rates than alternative single-use valves
- Provides an aseptic seal when in the closed position
- Allows for confident control of flow and shut-off with easy on/off knob

Typical Applications

- Single-use or disposable bioprocesses
- Sample collection
- Sterile transfers
- Product and media storage
- Tank connections — 0.625" ID sanitary connection



GORE™ Single-Use Valve

FOR STEAM-IN-PLACE APPLICATIONS

Typical Applications for the GORE™ Single-Use Valve

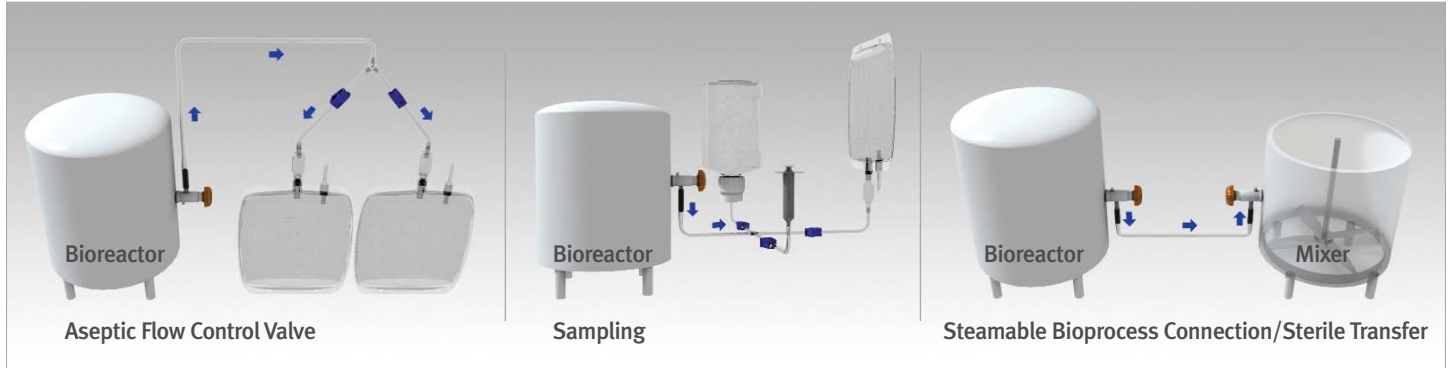

The GORE™ Single-Use Valve is an ideal choice for high-purity liquid operations that implement partial or total disposable bioprocessing components. The device creates a positive flow control with complete shut-off capability. The illustrations above show how the GORE™ Single-Use Valve can add value to applications such as sampling, steamable bioprocess connection, sterile transfer and aseptic flow control. Contact a Gore representative for more information on how the GORE™ Single-Use Valve can be incorporated into your process.

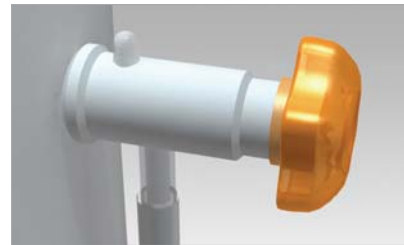

Dimensions (Inches)

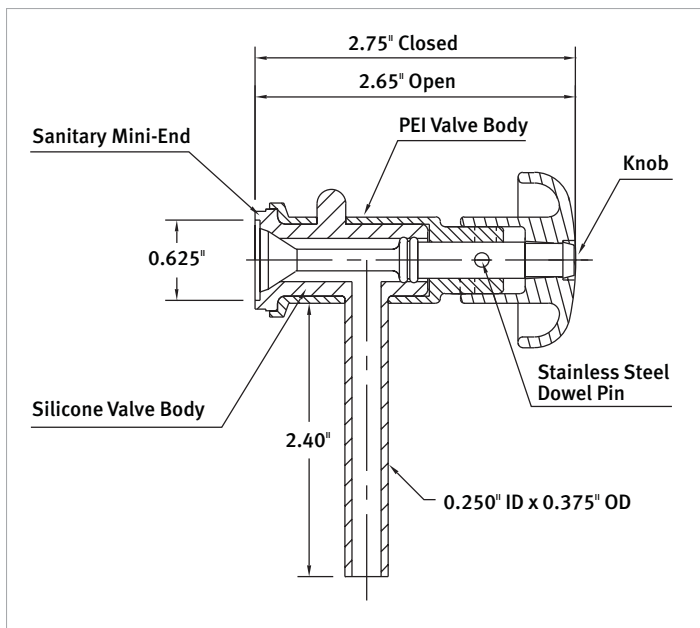



GORE™ Single-Use Valve

FOR STEAM-IN-PLACE APPLICATIONS

Performance Properties

GORE™ Single-Use Valve	ASTM Method	Specifications
Pressure Rating in closed position, psi	—	125
Pressure Rating in open position, psi	—	20
Maximum temperature, °C (°F)	—	130 (266)
Steam-in-place cycles	—	At a maximum, 2 times
Maximum recommended flow rate	—	6 L/min @ 5 psi

Typical Physical Properties

PCS Valve Body	ASTM Method	Specifications
Durometer hardness, Shore A	D2240	50
Tensile strength, psi	D412	1465
Specific gravity	D297	1.15
Temperature range, °C (°F)	—	-80 to 200 (-112 to 392)

PEI Housing	ASTM Method	Specifications
Heat deflection temperature at 66 psi, °C (°F)	D648	210 (410)
Izod impact, notched, 23°C, cm – kg / cm	D256	3

Ordering Information

Part Number	Connection (inches)	Outlet Tubing (inches)	Customization
ACS-9020	0.625 ID Mini sanitary end connections	0.250 ID x 0.375 OD	Sterilization, packaging, custom molding



GORE™ Single-Use Valve

FOR STEAM-IN-PLACE APPLICATIONS

Sterilization

It is the end-user's responsibility to validate a sterilization method when using the GORE™ Single-Use Valve. The end-user should conduct testing if sterilization conditions vary and/or if minor property changes could affect application performance.

Recommended sterilization methods include:

- Gas — Ethylene oxide
- Radiation — up to 40 kGy / 4.0 mRad maximum
- Steam — recommended maximum 2 SIP cycles prior to use

Customization

Building on a strong heritage of technical leadership and innovation, Gore continues to meet the demands of the marketplace by offering customers the ability to customize product offerings to meet specific needs. Customization options for the GORE™ Single-Use Valve include:

- Custom molding
- Packaging, including bagging and labeling
- Gamma sterilization

Shelf Life

When stored in the original unopened packaging at standard conditions, the GORE™ Single-Use Valve has a recommended shelf life of five years from the production date. When gamma irradiated, the GORE™ Single-Use Valve has a recommended shelf life of three years from the production date.

Contact Us

For detailed selection criteria, technical assistance and installation guidelines, please contact a Gore representative.

DISTRIBUTOR INFORMATION

To the best of our knowledge, the information contained herein is accurate. Final determination of the suitability of any information or material for the use contemplated and the manner of use is the sole responsibility of the user. The above information gives typical properties only.

GORE and design are trademarks of W. L. Gore & Associates, Inc.
© 2009 W. L. Gore & Associates, Inc. Printed in USA.

W. L. GORE & ASSOCIATES, INC. | GORE PHARMBIO PRODUCTS

402 Vieve's Way • Elkton, MD 21921 • USA

Phone: 410.506.1715 • Toll-Free: 800.294.4673 • pharmbio@wlgore.com

gore.com/pharmbio

